

HOMELITE

XL-76

CHAIN SAW

Leon's Chainsaw Parts & Repair
Do Not Sell Or Reproduce

HOMELITE-TERRY
TEXTRON

HOMELITE-TERRY
Division of Textron Canada Limited
Pointe Claire, Quebec



XL-76

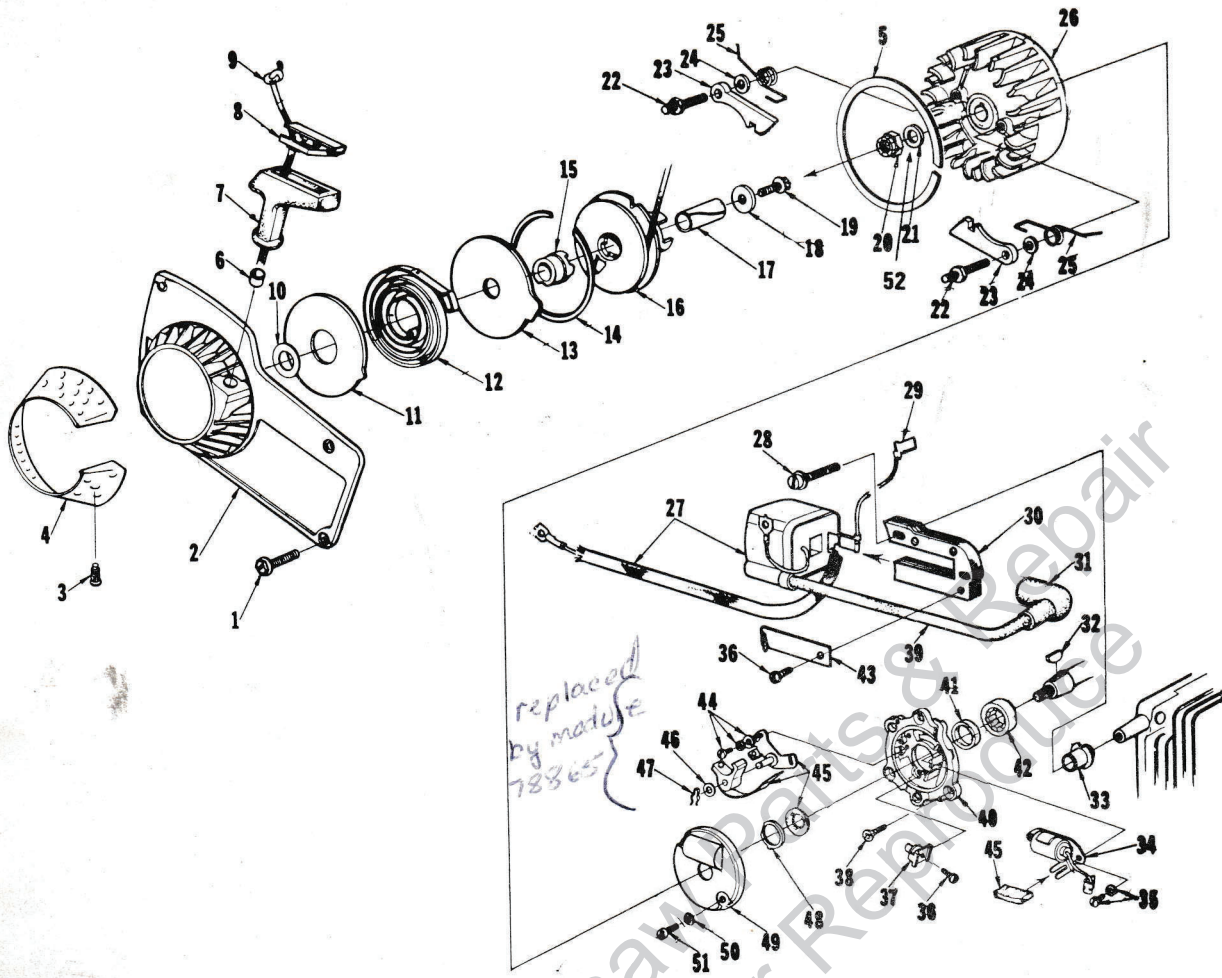

FIGURE 1

No.	Description	Part No.	Qty.	No.	Description	Part No.	Qty.
1	SCREW-hex, 10-32 x 1/2	80648	4	27	COIL-ignition	64091-AT	1
2	HOUSING-fan <i>178491</i>	A-67192-A	1	28	SCREW-coil core	82248	2
3	Includes: STUD-drive	67191	4	29	LEAD-ground to switch	A-63939	1
4	SCREEN-fan housing	65491	1	30	CORE-coil	54422	1
5	RING-air flow	67222	1	31	TERMINAL-spark plug	A-33055	1
6	BUSHING-starter rope	67177	1	32	KEY-woodruff	75078	1
7	GRIP-starting rope	64155-A	1	33	RETAINER-lead	64301	1
8	INSERT-rope retaining	68837-AT	1	34	CONDENSER & CLAMP	64086	1
9	ROPE-starter	63869	1	35	SCREW-condenser clamp	55411	2
10	WASHER	67185	1	36	SCREW	64090	2
11	SHIELD-spring (inner)	63713	1	37	BLOCK-terminal	64088	1
12	SPRING-rewind	63870	1	38	SCREW-back plate retainer	65321-A	5
13	SHIELD-spring (outer)	63714	1	39	LEAD-high tension	58966	1
14	RING-shield retaining	63875	1	40	PLATE-back	A-68142	1
15	LOCK-spring	64948	1	41	Includes: SEAL	12282-A	1
16	PULLEY & CUP ASSEMBLY <i>79090 A-63952-B</i>	64374	1	42	BEARING-roller	67395	1
17	BUSHING-starter post	64374	1	43	CLIP-coil retaining	54423	1
18	WASHER-retaining	63606	1	44	SCREW-breaker clamp	55411	2
19	SCREW-hex, 10-32 x 1/2	80648	1	45	POINT-set w/felt	<i>A-64087 178265</i>	1
20	NUT-jam, 5/16-24	81117	1	46	Includes: WASHER-post	28028	1
21	WASHER-flat, 5/16	84065-1	1	47	CLIP-post	28008	1
22	STUD-shoulder	63877-B	2	48	RETAINER-felt	64089	1
23	PAWL-starter	64442	2	49	COVER-breaker box	A-63928	1
24	WASHER-lock	70901	2	50	WASHER-flat #6	84018	2
25	SPRING-starter pawl	65375-1	2	51	SCREW-cover	64085	2
26	ROTOR-magneto <i>78900 63637</i>	63637	1	52	WASHER, lock	83030	1

XL-76

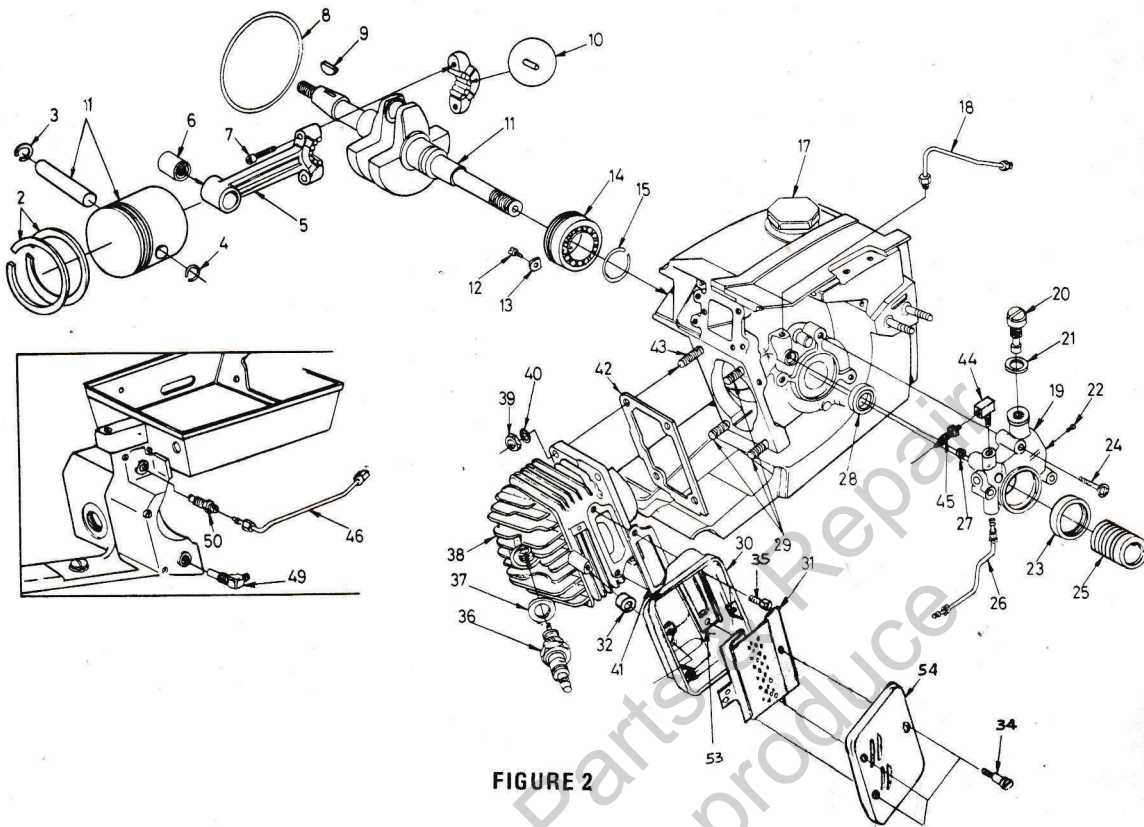

FIGURE 2

No.	Description	Part No.	Qty.	No.	Description	Part No.	Qty.
1	*PISTON & PIN 68438	A-121690 A78196	1	27	"O" RING	59074	1
	Includes:			28	SEAL	58308-B	1
2	PISTON RING	59436	2	29	STUD-cylinder (short)	55871	3
3	RING-retaining	75120	1	30	BODY-muffler	A-64130-2	1
4	RING-piston pin retaining	64813	1	31	BAFFLE-muffler	64126	1
5	ROD-connecting	A-68498-A	1	32	SPACER	84008	1
	Includes:			34	SCREW-shoulder	64133-A	2
6	BEARING-needle	67408 97566	1	35	SCREW-hex, 12-24 x 5/8	122403	3
7	SCREW	69919	2	36	SPARK PLUG (RJ-7)	78279	1
8	"O" RING	58785	1	37	Includes: GASKET	25038	1
9	KEY-Woodruff	75078	1	38	CYLINDER 78732	A-122325-A	1
10	ROLLER-needle (set of 25) 68495	A-69050	1	39	NUT-hex, 1/4-28	81065-2	4
11	CRANKSHAFT	68730	1	40	WASHER-lock, 1/4	83009	4
12	SCREW-Bearing retainer	70306	2	41	GASKET A78102	121474	1
13	WASHER-special	63905	2	42	GASKET-cylinder	65829	1
14	BEARING-ball	63865	1	43	STUD-cylinder (long)	63868	1
15	RING-retaining	58319-A	1	44	CONNECTOR-elbow	31734	1
17	CAP-fuel filler	A-69500		45	FITTING-straight	65696	1
18	LINE-oil (Auto. upper)	A-63919	1	46	LINE-oil (manual)	A-122198	1
19	PUMP-automatic oil	A-122342	1				
	Includes: Item 46						
20	SCREW-cam	64102-A		49	FILTER-oil	A-64741-T	1
21	GASKET	59736	1	50	VALVE-check	A-65948-1	1
22	SCREW-pan, 4-40 x 1/4	80919	2				
23	SEAL-felt	64393	1				
24	SCREW-pan 8-32 x 7/8	80568	3	53	PLATE-Muffler	64127	1
25	WORM-oil pump	63228	1			122302	
26	LINE-oil (auto. lower)	A-121734	1	54	CAP-Muffler	64125-1	1

SPECIAL TOOLS (available on order)					
A-122140	WRENCH-combination	23846-2	ANVIL-roller bearing disassembly	A-24057	BEARING REMOVER- (back plate)
22820-5	COLLAR-bearing installation (bearing to shaft)	A-122055	PULLER	24076	SLEEVE-seal protection (crankcase side)
22828	PLIERS-retaining ring	A-23949	TOOL-piston pin removal	24230	DRIVER-hand, pozidriv
23136-1	SLEEVE-bearing and shaft installation	A-23960	BRACKET-rotor removal	24173	DRIVER-check valve installation
23528	WRENCH-socket screw (connecting rod)	23972	SLEEVE-seal installation		
23756	PLUG-needle bearing (connecting rod)	24006-2	PLATE-shaft alignment	120875	BIT-pozidriv No. 2
23759	SLEEVE-seal protection (back plate)	A-24051	JACKSCREW (bearing to shaft to crankcase)		
		24054	PLUG-seal assembly (crankcase)		
		24055	PLUG-bearing and seal assembly (back plate)		
					ACCESSORIES
				65543-1	HEAT EXCHANGER
					PAINT
				23475	SPRAY CAN-red paint

XL-76

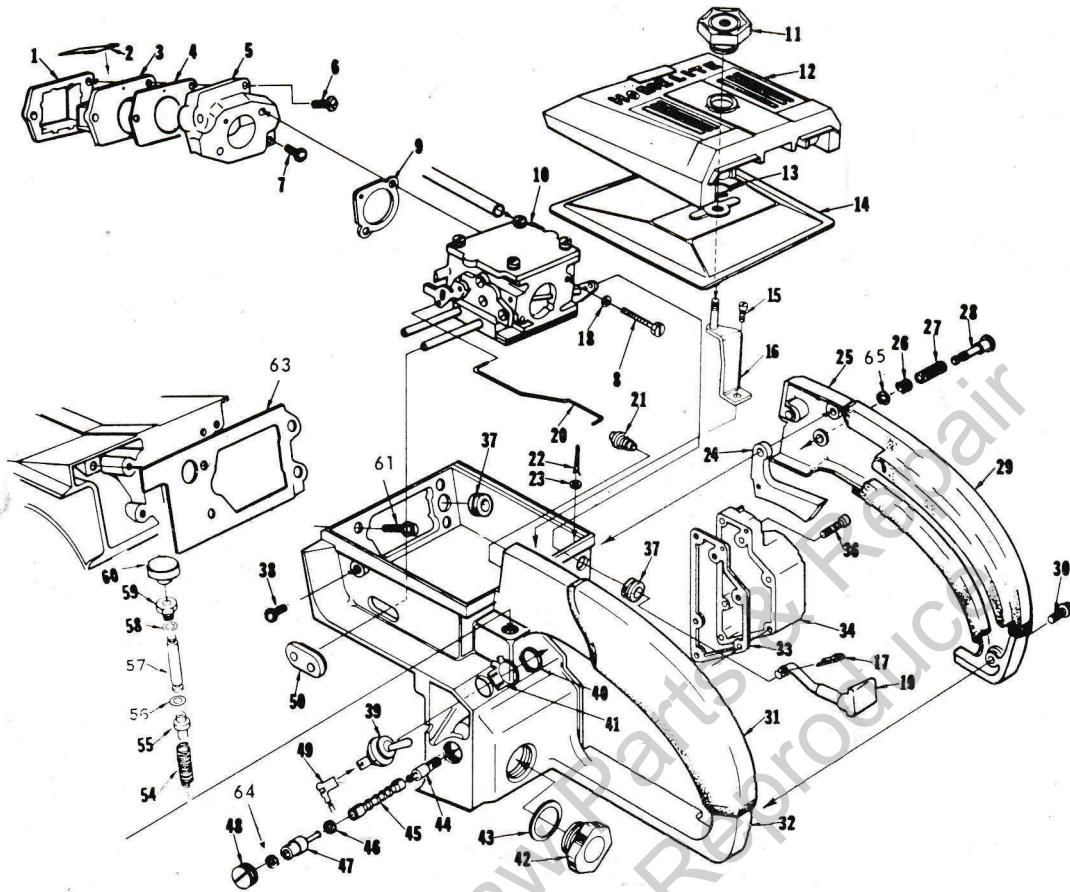
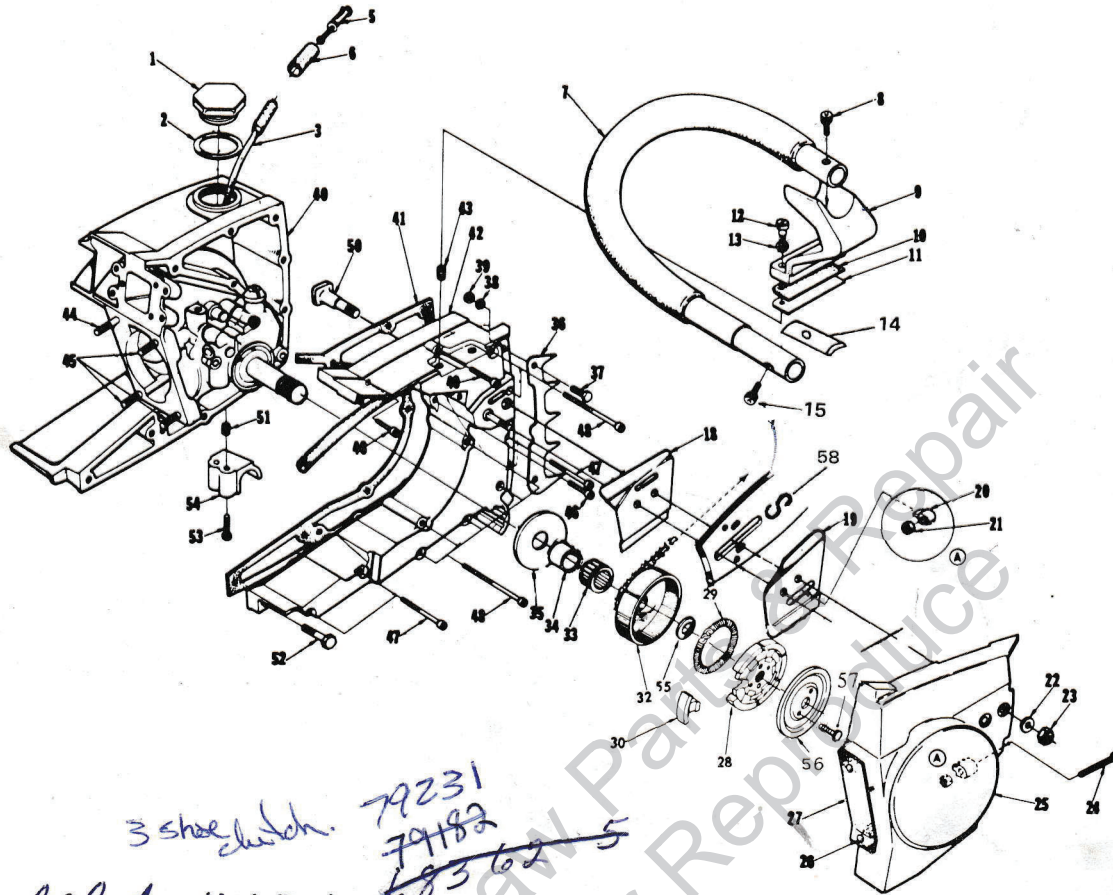

FIGURE 3

No.	Description	Part No.	Qty.	No.	Description	Part No.	Qty.
1	RETAINER-reed valve	64253-A	1	32	HANDLE-throttle	A-68483-T	1
2	REED-valve	59678-B	4		Includes:		
3	SEAT-reed valve	64252	1	33	GASKET-oil tank	67265	1
4	GASKET-reed valve seat	64266-T	1	34	COVER-oil tank	A-68120-A	1
5	MANIFOLD-intake	A-67502-A	1		Includes: PLUG-pipe (not shown)	59571	1
6	Includes: SCREW-pan, 8-32 x 1-1/4	82174	2	36	SCREW-fil, 8-32 x 3/4	82156	6
7	SCREW-pan, 8-32 x 1	82173	1	37	GROMMET	64862	2
8	SCREW-hex, 10-32 x 1-7/8	82179	2	38	PLUG	53572	1
9	GASKET-carburetor	67631	1	39	SWITCH	A-63938	1
10	CARBURETOR	A-78349	1	40	Includes: NUT	72084-A1	1
11	NUT-cover mounting	A-67627	1	41	PLATE-"On-Off"	63910	1
12	COVER-air filter	63183-7	1	42	CAP-oil (vented)	A-65284-AT	1
13	RING-retaining	58319-A	1	43	Includes: Gasket	69834	1
14	FILTER ELEMENT-air	A-63955-T	1		VALVE-vent (not shown)	69451	1
15	SCREW-hex, 12-24 x 1/2	80821	1	44	FILTER-oil (manual)	A-64293	1
16	BRACKET-air filter cover	A-63576	1	45	LINE-flexible oil	64356	1
17	PIN-cotter	86324	1	46	GASKET	59736	1
18	WASHER-lock, #10	83046	2	47	FITTING-check valve	A-63936	1
19	ROD-choke	67000-1	1	48	SCREW-set	63113	1
20	ROD-throttle	63896-A	1	49	LEAD-ground	A-63939	1
21	BOOT-throttle rod	67634	1	50	GROMMET-"Hi-Lo"	78140	1
22	PIN-cotter	86301	1	54	SPRING-plunger	65080	1
23	WASHER-felt	63290	1	55	PLUNGER-oil pump	65081-A	1
24	TRIGGER-throttle	63212-A	1	56	"O" RING	58406	1
25	COVER-throttle handle	63599-5	1	57	ROD plunger	A-121658	1
26	BUSHING-throttle lock	59064	1	58	Includes: "O" RING	59074	1
27	SPRING-throttle lock	58405	1	59	NUT-plunger	121293	1
28	PIN-throttle lock	58924-4	1	60	BUTTON-oil pump	57289-1	1
29	GRIP-throttle handle cover	68467	1	61	SCREW-hex, 12-24 x 5/8	80676	4
30	SCREW-pan, 8-32 x 1/2	80560	2	63	GASKET-throttle handle	64267-T	1
31	GRIP-throttle handle	68466	1	64	GROMMET	64474	1
				65	RING retaining	58409	1

XL-76



3 shoe clutch. 79231
 3 clutch XL76 79182
 68362 5

FIGURE 4

No.	Description	Part No.	Qty.	No.	Description	Part No.	Qty.
1	CAP-fuel filler	A-69499	1	33	BEARING-cage	64333	1
2	Includes: GASKET	69501	1	34	RACE-inner	63990	1
3	LINE-fuel	63544-A	1	35	WASHER-thrust (inner)	63860	1
5	FILTER-fuel	A-69923	1	36	BUMPER-spiked (optional)	A-64722	1
6	Includes: FILTER-felt	64083	1	37	Includes: SCREW-hex, 12-24 x 5/8	80676	2
7	HANDLE BAR-flush cut	A-122135	1	38	WASHER-lock, no. 12	83056	2
8	SCREW-Fil., 10-32 x 1	80041	1	39	NUT-hex, 12-24	81068	2
9	BRACKET-handle bar	A-68995	1	40	CRANKCASE & TANK	A-68439-AT	1
10	PAD-bracket	64610	1		Includes: PIN-dowel (not shown)	71430	2
11	PLATE-handle bar bracket	65586	1		PIN-dowel (not shown)	65365	2
12	SCREW-shoulder	68338	2		SEAL-(see fig. 2, Index No. 28)	58308-B	1
13	GROMMET-handle bar bracket	64474	2	41	GASKET-fuel tank	65364-A	1
14	SPACER	122132	1	42	COVER-fuel tank	A-68040-AT	1
15	SCREW-Fil., Hd. 1/4 - 20 x 1-1/8	122064	1		Includes:		
18	PLATE-guide bar (inner)	70397	1	43	INSERT-taplock	72489	2
19	PLATE-guide bar (outer)	70398	1	44	STUD-cylinder (long)	63868	1
20	PIN-bar adjusting	65768-1	1	45	STUD-cylinder (short)	69438	3
21	NUT-lock, 10-32	81109-2	1	46	SCREW-fil, 8-32 x 15/16	82151	2
22	WASHER-flat, 5/16	84032	2	47	SCREW-fil, 8-32 x 1-7/8	82154	3
23	NUT-hex, 5/16-18	81196	2	48	SCREW-fil, 8-32 x 2-3/16	82155	7
24	SCREW-guide bar adjusting	65175-A	1	49	SCREW-fil, 8-32 x 1-1/4	82152	1
25	COVER-drivecase	A-64620-2CT	1	50	BOLT-guide bar	67193	2
26	Includes: RIVET-oval head	85016	2	51	INSERT-taplock	72489	2
27	SHIELD-sawdust	64618	1	52	SCREW-hex, 12-24 x 7/8	80891	1
28	SPIDER-clutch	78401	1	53	SCREW-pan, 10-32 x 5/8	80572	2
29	SPRING-clutch	67441	2	54	STOP-handle bar	67506-2	1
30	SHOE-clutch	69754-1B	6	55	WASHER, Thrust	78111	1
32	SPROCKET & DRUM-3/8 pitch, 7 tooth	A-59553-IT	1		HANDLE BAR (wrap-around) - optional	A-122163-1	
		728909		56	COVER, Clutch	58751-1	1
		A 95459-1		57	SCREW, Hex. Hd. (10-32 x 1/2)	78333	2
				58	CLIP, "S"	69966	1

XL-76

A-78349
HS-125-B

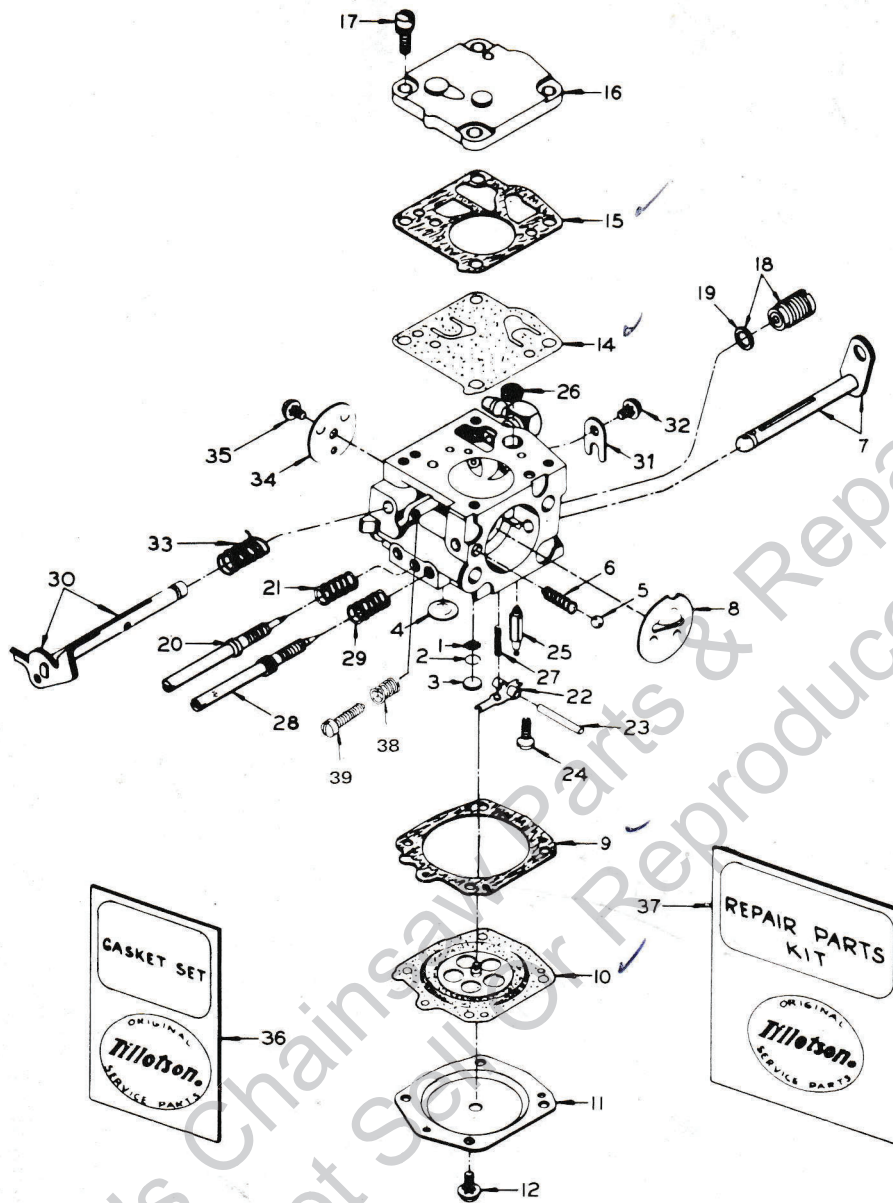

No.	Description	Part No.	Qty.	No.	Description	Part No.	Qty.
1	Body Channel Screen	78137		22	*Inlet Control Lever	59716	1
2	Body Channel Screen Ret. Ring	57819	1	23	*Inlet Pinion Pin	58977	1
3	*Body Channel Welch Plug (Small)	58994	1	24	*Inlet Pinion Pin Ret. Screw	65798	1
4	*Body Channel Welch Plug (Large)	58991	1	25	Inlet Needle	59717	1
5	Choke Friction Ball	25527	2	26	*Inlet Screen	78132	1
6	Choke Friction Spring	73264	1	27	*Inlet Tension Spring	65603	1
7	Choke Shaft & Lever	78134	1	28	High Speed Mixture Screw	78136	1
8	Choke Shutter	58984	1	29	*High Speed Mixture Screw Spring	73075	1
9	Diaphragm Gasket	58978	1	30	Throttle Shaft & Lever	A-69153	1
10	*Diaphragm	58988	1	31	Throttle Shaft Clip	58982	1
11	Diaphragm Cover	58979	1	32	Throttle Shaft Clip Ret. Screw & Lockwasher	80264	2
12	Diaphragm Cover Ret. Screw & Lockwasher(4)	80591	4	33	*Throttle Shaft Return Spring	-	1
14	*Fuel Pump Diaphragm	58980-R	1	34	Throttle Shutter	67994	1
15	Fuel Pump Gasket	58981	1	35	*Throttle Shutter Screw	80264	2
16	Fuel Pump Cover	58975	1	36	*Gasket Set	67866	1
17	Fuel Pump Cover Ret. Screw & Lockwasher(4)	80275	4	37	Repair Kit	78112	1
18	Governor Valve Assembly	78133	1				
19	Governor Valve Assembly Gasket	74060	1		* Indicates contents of Repair Kit		
20	Idle Mixture Screw	78135	1	38	SPRING, Idle Speed	58973	1
21	*Idle Mixture Screw Spring	54440	1	39	SCREW, Idle Speed	58993	1

ALWAYS FURNISH MODEL AND SERIAL NUMBER WHEN ORDERING PARTS.

MODEL SAW XL 76

All units bearing UT number 50139 and up are manufactured with CD ignition.

Module and core P/N ⁷⁸⁶¹~~78647~~ replaces item 27 coil ignition.

Item 38 cylinder A-122325A is replaced with cylinder A-78732.

Item 2 housing fan A-78491 is replaced with housing fan A-78731.

Item 11 crankshaft 68730 is replaced with crankshaft 68730-T.

ITEMS ADDED:

Spacer bracket P/N 78636 cylinder to module and core P/N 78636 qty. 1.

Spacer starter pawl P/N 78635 qty. 2.

Lead ground P/N A-59031 replaces P/N A-63939.

Leon's Chainsaw Parts & Repair
Do Not Sell Or Reproduce