

# HOMELITE

**XL-76**

**CHAIN SAW**

**TYPE OR UT NO. 50108**

**HOMELITE-TERRY**  
**TEXTRON**

HOMELITE-TERRY  
Division of Textron Canada Limited  
Pointe Claire, Quebec



# XL-76

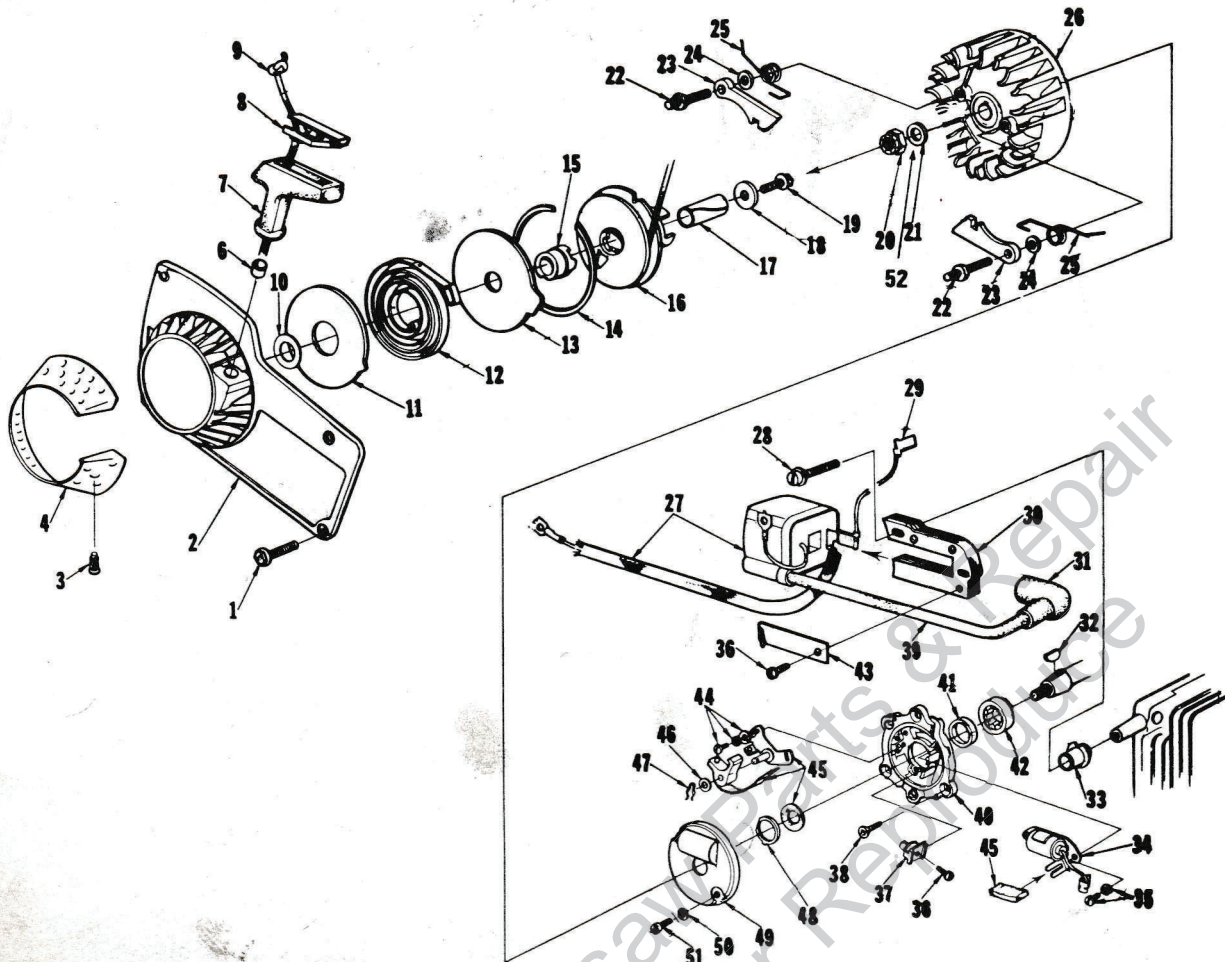

**FIGURE 1**

No.	Description	Part No.	Qty.	No.	Description	Part No.	Qty.	
1	SCREW-hex, 10-32 x 1/2	80648	4	28	SCREW-coil core	82248	2	
2	HOUSING-fan includes #6	A-78491	1	29	LEAD-ground to switch	A-63939	1	
3	Optional {	STUD-drive	67191	4	30	CORE-coil	54422	1
4		SCREEN-fan housing	65491	1	31	TERMINAL-spark plug	A-33055	1
6	BUSHING-starter rope	67177	1	32	KEY-woodruff	75078	1	
7	GRIP-starting rope	64155-A	1	33	RETAINER-lead	64301	1	
8	INSERT-rope retaining	68837-AT	1	34	CONDENSER & CLAMP	64086	1	
9	ROPE-starter	63869	1	35	SCREW-condenser clamp	55411	2	
10	WASHER	67185	1	36	SCREW	64090	2	
11	SHIELD-spring (inner)	63713	1	37	BLOCK-terminal	64088	1	
12	SPRING-rewind	63870	1	38	SCREW-back plate retainer	65321-A	5	
13	SHIELD-spring (outer)	63714	1	39	LEAD-high tension	58966	1	
14	RING-shield retaining	63875	1	40	PLATE-back	A-68142	1	
15	LOCK-spring	64948	1	41	Includes: SEAL	12282-A	1	
16	PULLEY & CUP ASSEMBLY <i>79090A-63952-B</i>	79090A-63952-B	1	42	BEARING-roller	67395	1	
17	BUSHING-starter post	64374	1	43	CLIP-coil retaining	54423	1	
18	WASHER-retaining	63606	1	44	SCREW-breaker clamp	55411	2	
19	SCREW-hex, 10-32 x 1/2	80648	1	45	POINT-set w/felt	A-64087	1	
20	NUT-jam, 5/16-24	81117	1	46	Includes: WASHER-post	28028	1	
21	WASHER-flat, 5/16	84065-1	1	47	CLIP-post	28008	1	
22	STUD-shoulder	58757-E	2	48	RETAINER-felt	64089	1	
23	PAWL-starter	64442	2	49	COVER-breaker box	A-63928	1	
24	WASHER-lock	70901	2	50	WASHER-flat #6	84018	2	
25	SPRING-starter pawl	65375-1	2	51	SCREW-cover	64085	2	
26	ROTOR-magneto	<i>78900-63097</i>	1	52	WASHER, lock	83030	1	
27	COIL-ignition	64091-AT	1					

# XL-76

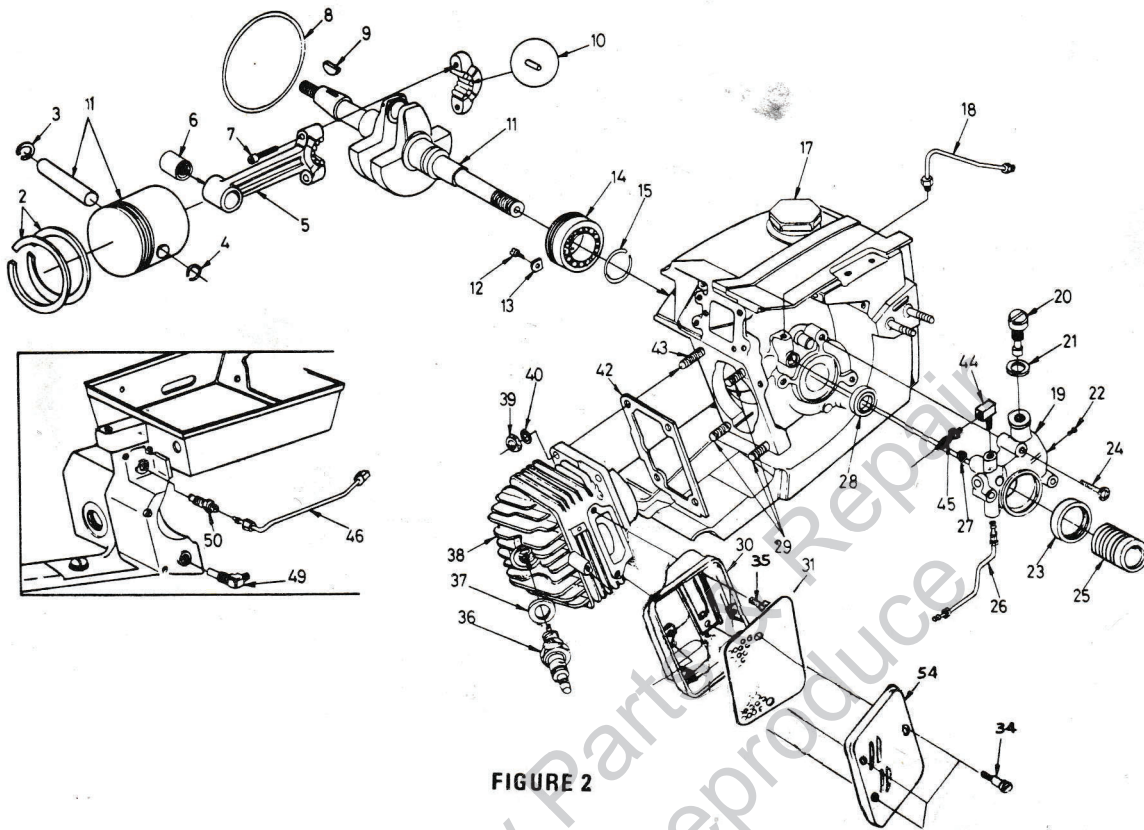

**FIGURE 2**

No.	Description	Part No.	Qty.	No.	Description	Part No.	Qty.
1	*PISTON & PIN Includes:	A-78496	1	24	SCREW-pan 8-32 x 7/8	80568	3
2	PISTON RING	59436	2	25	WORM-oil pump	63228	1
3	RING-retaining	75120	1	26	LINE-oil (auto. lower)	A-78105	1
4	RING-piston pin retaining	64813	1	27	"O" RING	59074	1
5	ROD-connecting Includes:	A-68498-A	1	28	SEAL	58308-B	1
6	BEARING-needle	67408	1	29	STUD-cylinder (short)	55871	3
7	SCREW	69919	2	30	BODY-muffler	A-64130-2	1
8	"O" RING	58785	1	31	BAFFLE-muffler	64126	1
9	KEY-Woodruff	75078	1	34	SCREW-shoulder	64133-A	2
10	ROLLER-needle (set of 25)	A-69050	1	35	SCREW-hex, 12-24 x 5/8	78156	3
11	CRANKSHAFT	68730	1	36	SPARK PLUG (RJ-7)	78279	1
12	SCREW-Bearing retainer	70306	2	37	Includes: GASKET	25038	1
13	WASHER-special	63905	2	38	CYLINDER	<del>A-78160</del> 78732	1
14	BEARING-ball	63865	1	39	NUT-hex, 1/4-28	81065-2	4
15	RING-retaining	58319-A	1	40	WASHER-lock, 1/4	83009	4
17	CAP-fuel filler	A-69500	1	42	GASKET-cylinder	65829	1
18	LINE-oil (Auto, upper)	A-78456	1	43	STUD-cylinder (long)	63868	1
19	PUMP-automatic oil Includes: Item 44 & 45	A-67023-T	1	44	CONNECTOR-elbow	31734	1
20	SCREW-cam	64102-A	1	45	FITTING-straight	65696	1
21	GASKET	59736	1	46	LINE-oil (manual)	A-78131	1
22	SCREW-pan, 4-40 x 1/4	80919	2	49	FILTER-oil	A-64741-T	1
23	SEAL-felt	64393	1	50	VALVE-check	A-65948-1	1
				54	CAP-Muffler	64125-1	1

**SPECIAL TOOLS (available on order)**

22820-5	COLLAR-bearing installation (bearing to shaft)	A-23949
22828	PLIERS-retaining ring	A-23960
23136-1	SLEEVE-bearing and shaft installation	23972
23528	WRENCH-socket screw (connecting rod)	24006-2
23756	PLUG-needle bearing (connecting rod)	A-24051
23759	SLEEVE-seal protection (back plate)	24054

23846-2	ANVIL-roller bearing disassembly
A-23949	TOOL-piston pin removal
A-23960	BRACKET-rotor removal
23972	SLEEVE-seal installation
24006-2	PLATE-shaft alignment
A-24051	JACKSCREW (bearing to shaft to crankcase)
24054	PLUG-seal assembly (crankcase)
24055	PLUG-bearing and seal assembly (back plate)

A-24057	BEARING REMOVER- (back plate)
24076	SLEEVE-seal protection (crankcase side)
24230	DRIVER-hand, pozidriv
24173	DRIVER-check valve installation
24982	BIT - TORX-for 70306 screw
120875	BIT-pozidriv No. 2

**ACCESSORIES**

65543-1	HEAT EXCHANGER
<b>PAINT</b>	
23475	SPRAY CAN-red paint

# XL-76

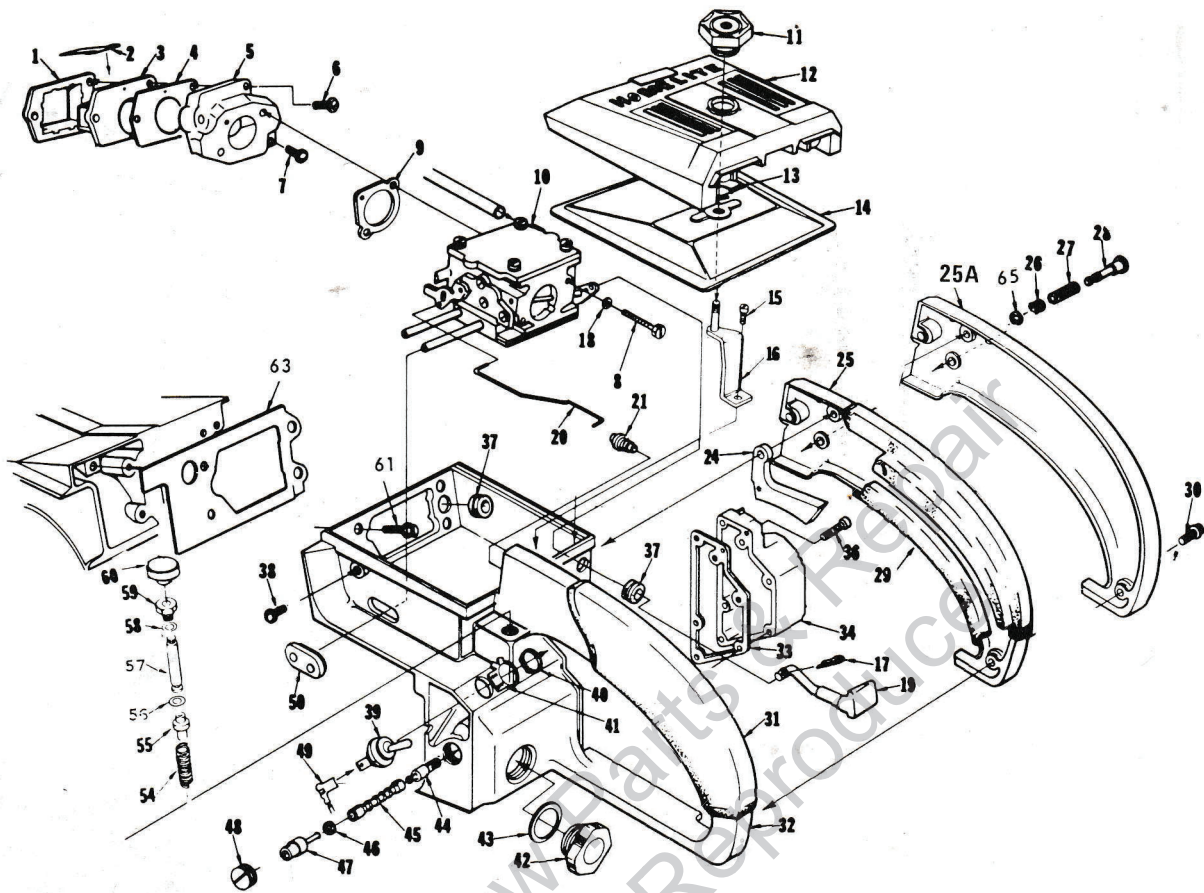

**FIGURE 3**

No.	Description	Part No.	Qty.	No.	Description	Part No.	Qty.
1	RETAINER-reed valve	64253-A	1	32	HANDLE-throttle	A-68483-T	1
2	REED-valve	59678-B	4		Includes: Item 29 & 31		
3	SEAT-reed valve	64252	1	33	GASKET-oil tank	67265	1
4	GASKET-reed valve seat	64266-T	1	34	COVER-oil tank	A-68120-A	1
5	MANIFOLD-intake	A-67502-A	1		Includes: PLUG-pipe (not shown)	59571	1
6	Includes: SCREW-pan, 8-32 x 1-1/4	82174	2				
7	SCREW-pan, 8-32 x 1	82173	1	36	SCREW-fil, 8-32 x 3/4	82156	6
8	SCREW-hex, 10-32 x 1-7/8	82179	2	37	GROMMET	64862	2
9	GASKET-carburetor	67631	1	38	PLUG	53572	1
10	CARBURETOR	A-78349	1	39	SWITCH	A-63938	1
11	NUT-cover mounting	A-67627	1	40	Includes: NUT	72084-A1	1
12	COVER-air filter	63183-7	1	41	PLATE-"Run-Stop"	70834	1
13	RING-retaining	58319-A	1	42	CAP-oil (vented)	A-65284-AT	1
14	FILTER ELEMENT-air	A-63955-T	1	43	Includes: Gasket	69834	1
15	SCREW-hex, 12-24 x 1/2	80821	1		VALVE-vent (not shown)	69451	1
16	BRACKET-air filter cover	A-63576	1	44	FILTER-oil (manual)	A-64293	1
17	PIN-cotter	86324	1	45	LINE-flexible oil	64356	1
18	WASHER-lock, #10	83046	2	46	GASKET	59736	1
19	ROD-choke	67000-1	1	47	FITTING-check valve	A-63936	1
20	ROD-throttle	63896-A	1	48	SCREW-set	63113	1
21	BOOT-throttle rod	67634	1	49	LEAD-ground	A-63939	1
24	TRIGGER-throttle	63212-A	1	50	GROMMET-"Hi-Lo"	78140	1
25	COVER-throttle handle	63599-5	1	54	SPRING-plunger	65080	1
25A	COVER-without item 29	63599-3	1	55	PLUNGER-oil pump	65081-A	1
26	BUSHING-throttle lock	59064	1	56	"O" RING	58406	1
27	SPRING-throttle lock	58405	1	57	ROD plunger	A-78103	1
28	PIN-throttle lock	58924-4	1	58	Includes: "O" RING	59074	1
29	GRIP-throttle handle cover	68467	1	59	NUT-plunger	78100	1
30	SCREW-pan, 8-32 x 1/2	80560	2	60	BUTTON-oil pump	57289-1	1
31	GRIP-throttle handle	68466	1	61	SCREW-hex, 12-24 x 5/8	80676	4
				63	GASKET-throttle handle	64267-T	1
				65	RING retaining	58409	1

# XL-76

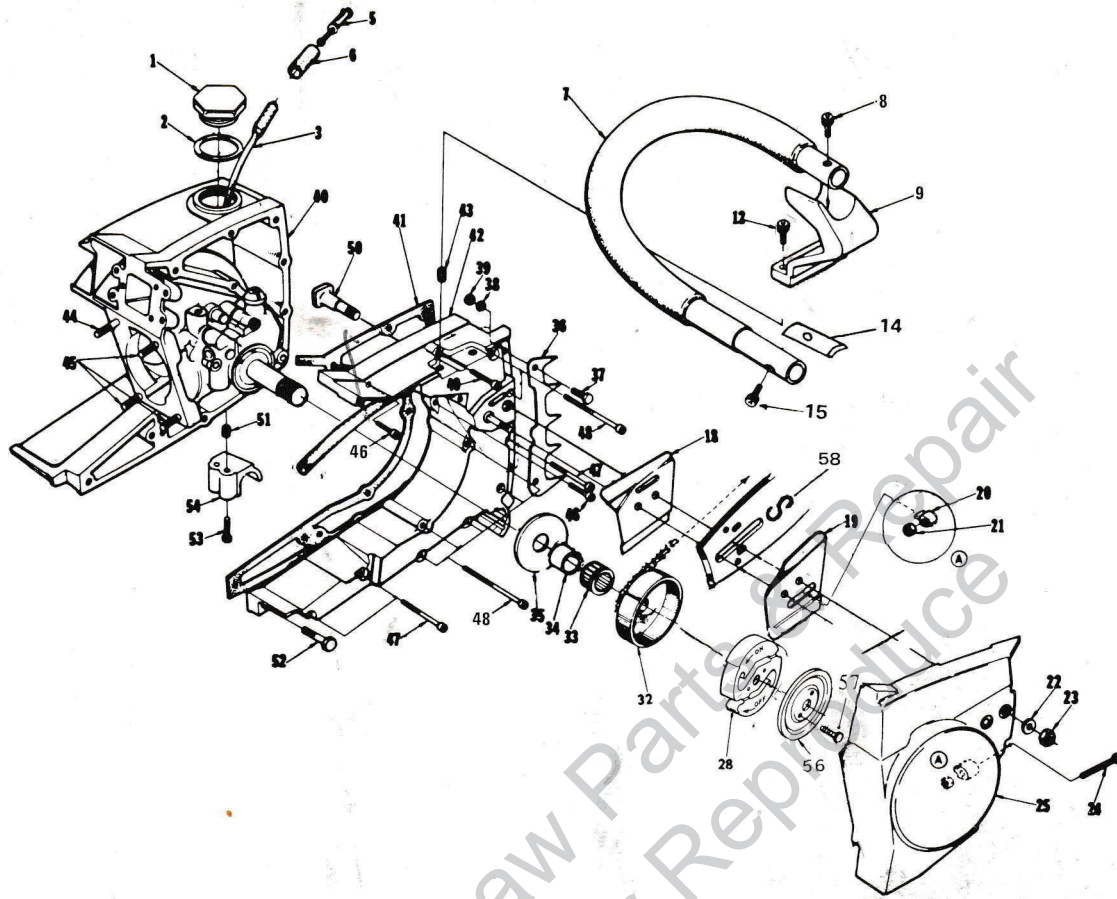
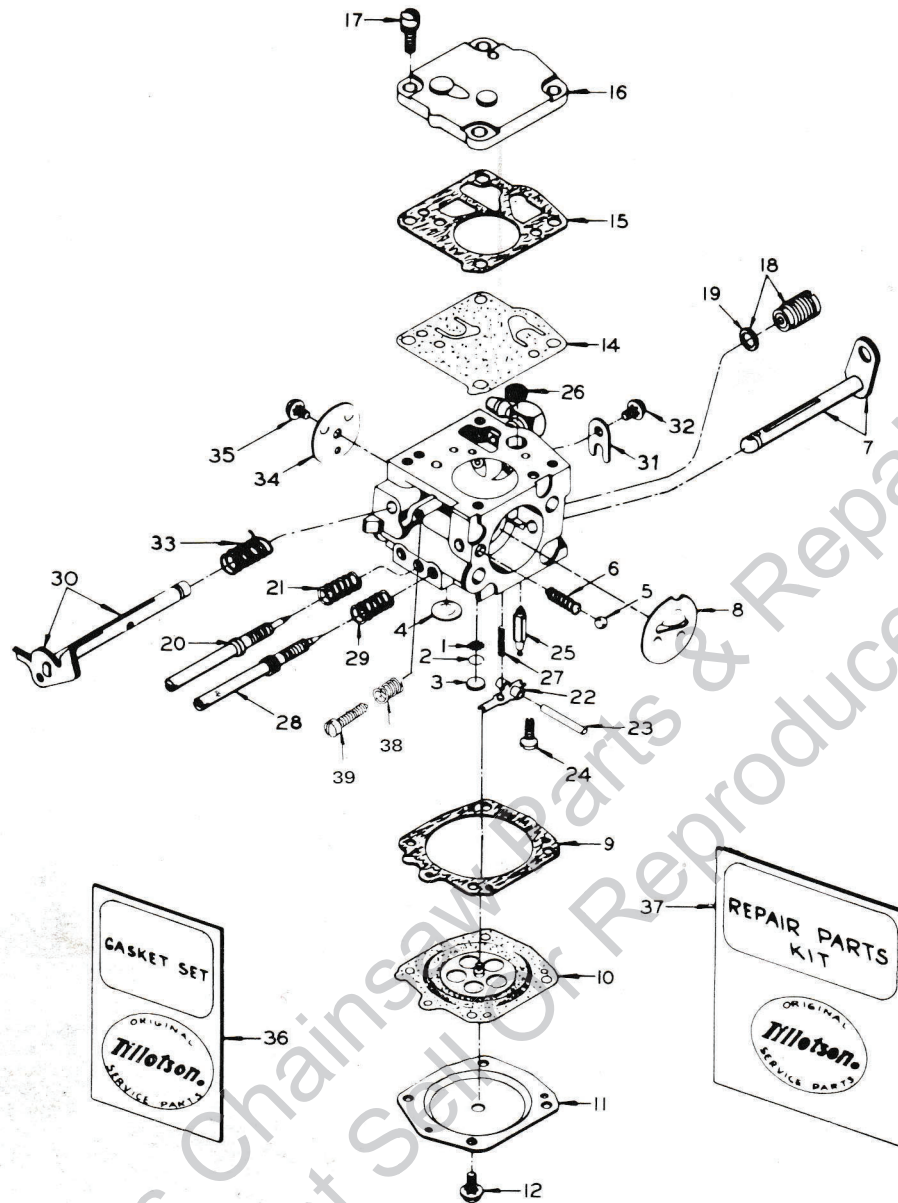

FIGURE 4

No.	Description	Part No.	Qty.	No.	Description	Part No.	Qty.
1	CAP-fuel filler	A-69499	1	36	BUMPER-spiked (optional)	A-64722	1
2	Includes: GASKET	69501	1	37	Includes: SCREW-hex, 12-24 x 5/8	80676	2
3	LINE-fuel	63544-A	1	38	WASHER-lock, no. 12	83056	2
5	FILTER-fuel	A-69923	1	39	NUT-hex, 12-24	81068	2
6	Includes: FILTER-felt	64083	1	40	CRANKCASE & TANK	A-68439-AT	1
7	HANDLE BAR-flush cut	A-78509	1	Includes: PIN-dowel (not shown)	71430	2	
8	SCREW-Fil., 10-32 x 1	80041	1	Includes: PIN-dowel (not shown)	65365	2	
9	BRACKET-handle bar	A-78474	1	SEAL-(see fig. 2, Index No. 28)	58308-B	1	
12	SCREW-hex. hd. #10-32" x 7/8	82268	2	41	GASKET-fuel tank	65364-A	1
14	SPACER	78485	1	42	COVER-fuel tank	A-68040-AT	1
15	SCREW-Fil., Hd. 1/4 - 20 x 1-1/8	78117	1	Includes:			
18	PLATE-guide bar (inner)	70397	1	43	INSERT-taplock	72489	2
19	PLATE-guide bar (outer)	70398	1	44	STUD-cylinder (long)	63868	1
20	PIN-bar adjusting	65768-1	1	45	STUD-cylinder (short)	69438	3
21	NUT-lock, 10-32	81109-2	1	46	SCREW-fil, 8-32 x 15/16	82151	2
22	WASHER-flat, 5/16	84032	2	47	SCREW-fil, 8-32 x 1-7/8	82154	3
23	NUT-hex, 5/16-18	81196	2	48	SCREW-fil, 8-32 x 2-3/16	82155	7
24	SCREW-guide bar adjusting	65175-A	1	49	SCREW-fil, 8-32 x 1-1/4	82152	1
25	COVER-drivecase	78476	1	50	BOLT-guide bar	67193	2
28	CLUTCH	<del>73193</del> <del>68825</del>	1	51	INSERT-taplock	72489	2
32	SPROCKET & DRUM-3/8 pitch, 7 tooth	A-69436 <del>68825</del> 96522	1	52	SCREW-hex, 12-24 x 7/8	80891	1
33	BEARING-cage	64333	1	53	SCREW-pan, 10-32 x 5/8	80572	2
34	RACE-inner	63990	1	54	STOP-handle bar	67506-2	1
35	WASHER-thrust (inner)	63860	1	HANDLE BAR (wrap-around) - optional	A-78460-1		
				56	COVER, Clutch	69915	1
				57	SCREW, Hex. Hd. (10-32 x 1/2)	78333	2
				58	CLIP, "S"	69966	1

# XL-76

A-78349  
HS-125-B



No.	Description	Part No.	Qty.	No.	Description	Part No.	Qty.
1	Body Channel Screen	78137		22	*Inlet Control Lever	59716	1
2	Body Channel Screen Ret. Ring	57819	1	23	*Inlet Pinion Pin	58977	1
3	*Body Channel Welch Plug (Small)	58994	1	24	*Inlet Pinion Pin Ret. Screw	65798	1
4	*Body Channel Welch Plug (Large)	58991	1	25	Inlet Needle	59717	1
5	Choke Friction Ball	25527	2	26	*Inlet Screen	78132	1
6	Choke Friction Spring	73264	1	27	*Inlet Tension Spring	65603	1
7	Choke Shaft & Lever	78134	1	28	High Speed Mixture Screw	78136	1
8	Choke Shutter	58984	1	29	*High Speed Mixture Screw Spring	73075	1
9	Diaphragm Gasket	58978	1	30	Throttle Shaft & Lever	A-69153	1
10	*Diaphragm	58988	1	31	Throttle Shaft Clip	58982	1
11	Diaphragm Cover	58979	1	32	Throttle Shaft Clip Ret. Screw & Lockwasher	80264	2
12	Diaphragm Cover Ret. Screw & Lockwasher(4)	80591	4	33	*Throttle Shaft Return Spring		1
13	*Fuel Pump Diaphragm	58980-R	1	34	Throttle Shutter	67994	1
14	Fuel Pump Gasket	58981	1	35	*Throttle Shutter Screw	80264	2
15	Fuel Pump Cover	58975	1	36	*Gasket Set	67866	1
16	Fuel Pump Cover Ret. Screw & Lockwasher(4)	80275	4	37	Repair Kit	78112	1
17	Governor Valve Assembly	78133	1		* Indicates contents of Repair Kit		
18	Governor Valve Assembly Gasket	74060	1	38	SPRING, Idle Speed	58973	1
19	Idle Mixture Screw	78135	1	39	SCREW, Idle Speed	58993	1
20	*Idle Mixture Screw Spring	54440	1				

ALWAYS FURNISH MODEL AND SERIAL NUMBER WHEN ORDERING PARTS.

PARTS LIST ADDEMDUM

P/N 78739

MODEL SAW XL 76

All units bearing UT number 50139 and up are manufactured with CD ignition.

Module and core P/N 78647 replaces item 27 coil ignition.

Item 38 cylinder A-122325A is replaced with cylinder A-78732.

Item 2 housing fan A-78491 is replaced with housing fan A-78731.

Item 11 crankshaft 68730 is replaced with crankshaft 68730-T.

ITEMS ADDED:

Spacer bracket P/N 78636 cylinder to module and core P/N 78636 qty. 1.

Spacer starter pawl P/N 78635 qty. 2.

Lead ground P/N A-59031 replaces P/N A-63939.

Leon's Chainsaw Parts & Repair  
Do Not Sell Or Reproduce