

HOMELITE®

XL-2

PARTS LIST

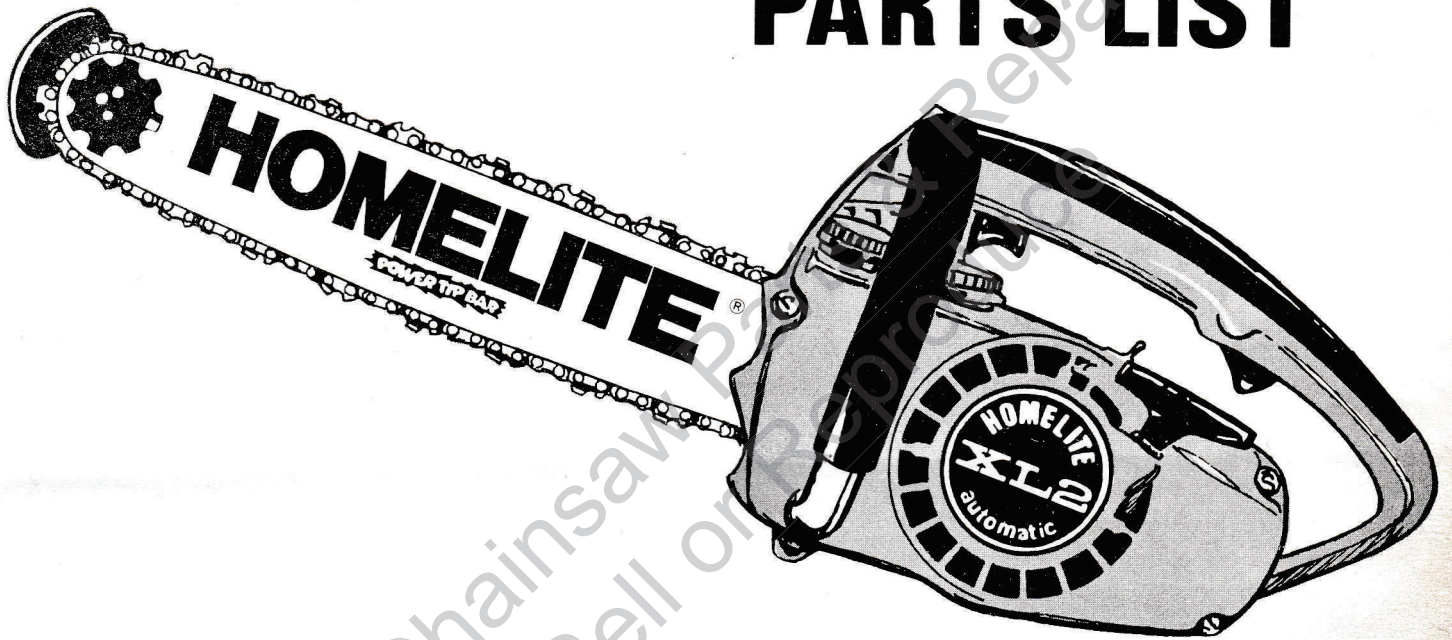

*Automatic
Oiling
Chain Saw*

HOMELITE-TERRY **TEXTRON**

Homelite-Terry Division of Textron Canada Limited

XL-2

FIGURE 1

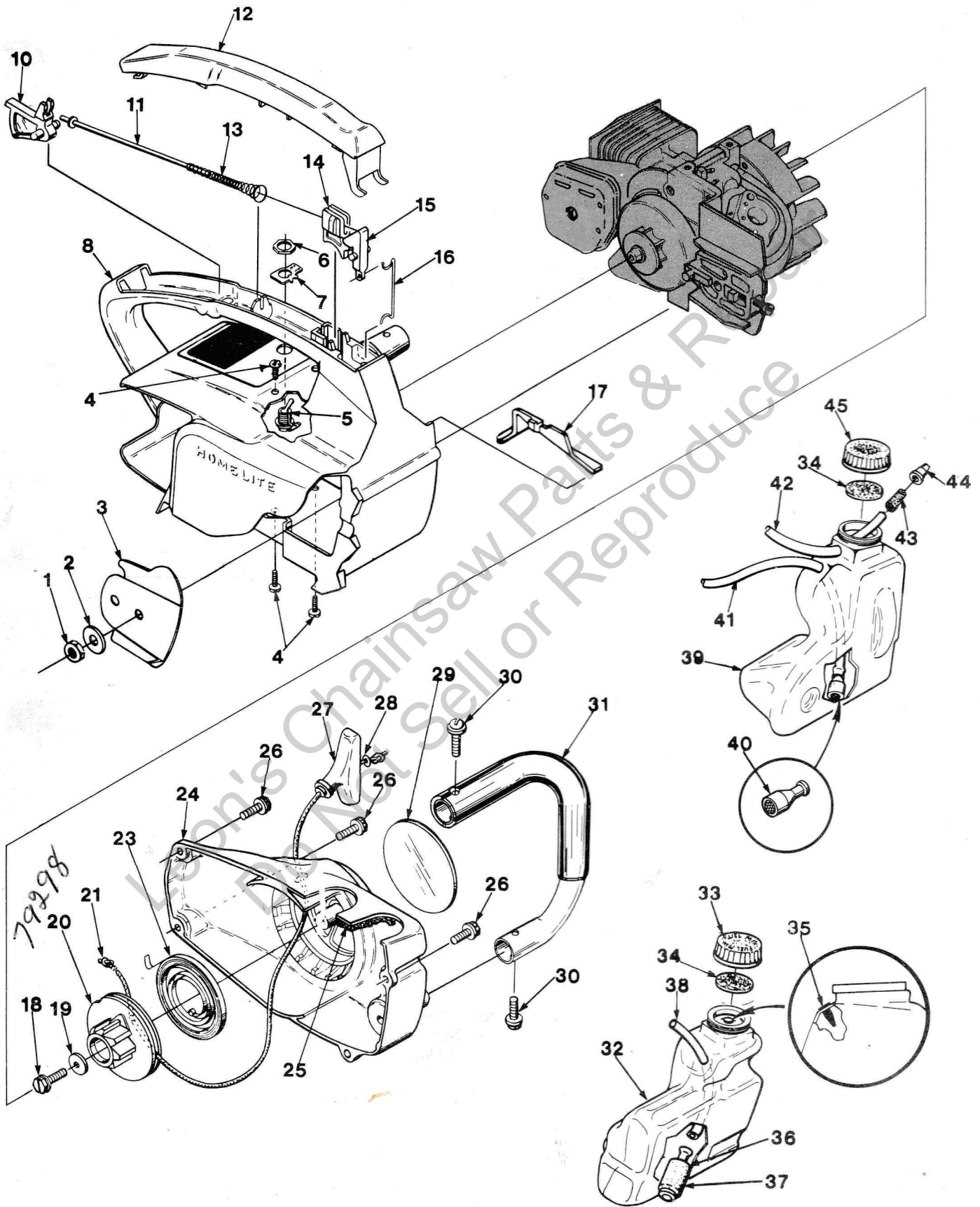

XL-2

FIGURE 1

No.	Description	Part No.	Qty.	No.	Description	Part No.	Qty.
1	NUT- Guide bar, 1/4 - 28	81065-2	1	30	SCREW- Pan washer hd., 10-32 x 5/8	82239	2
2	WASHER- Flat	69309-1	1	31	HANDLE BAR	A-70219-1	1
3	PLATE- Guide bar	69360	1	32	TANK- Fuel	A-70899	1
4	SCREW- Pan hd., 10-24 x 1/2	82216	4		Includes:		
5	SWITCH- Stop (grounding)	A-63938	1	33	CAP- Tank fuel (red) (Note 1)	A-70894-A	1
	Includes:				Includes:		
6	NUT- Hex	72084-A1	1	34	GASKET- Fuel filler cap (Note 2)	94838-A	2
7	PLATE- "On-Off"	70834	1	35	VALVE- Check (duck bill)	69451	1
8	HOUSING-Engine	A-69882-T	1	36	FILTER- Fuel	A-69923	1
	Includes:				Includes:		
10	TRIGGER- Rear	69106-A	1	37	ELEMENT- Felt	64083	1
11	ROD- Throttle	A-69136	1	38	LINE- Fuel	70310-29	1
12	COVER- Handle	69140-A	1	39	TANK- Oil	A-70898	1
13	SPRING- Throttle rod	69249	1		Includes:		
14	TRIGGER- Front	69105	1	40	FILTER- Oil	A-68593	1
15	LEVER- Throttle	69107	1	41	LINE- Oil	93112-24	1
16	ROD- Throttle (front)	69255-C	1	42	LINE- Pressure	A-69358	1
17	COVER- Air filter	69263	1		Includes:		
18	SCREW- Hex washer hd., 10-32 x 5/8	80704	1	43	CONNECTOR- Oil	69659-1A	1
19	WASHER-Flat	63606-1	1	44	VALVE- Check (duck bill)	69451	1
20	PULLEY-Starter	69158	1	45	CAP- Tank (Oil) (Black) (Note 1)	A-70893-A	1
21	ROPE-Starter #4, 34" long	69311-A	1		Includes:		
	Includes:				GASKET- Fuel filler cap (Note 2)	94838-A	1
23	SPRING- Rewind	69217	1		(see #34)		
24	HOUSING- Rewind starter	A-69540	1				
	Includes:						
25	FILTER- Fuel tank valve	69443	1				
26	SCREW- Hex 10-32 x 5/8	80704	4				
27	GRIP- Starter rope	70211	1				
28	WASHER- Flat	84025	1				
29	DECAL- XL-2	69346	1				

NOTE 1: Tanks with internal threads require A-70445 Fuel cap and A-70446 Oil cap. If internal threads in tank are worn order new external threaded tank.

NOTE 2: Use 70826 Gasket in A-70893 and A-70894 external thread caps. Use 69585 gasket for caps with internal threads.

XL-2

FIGURE 2

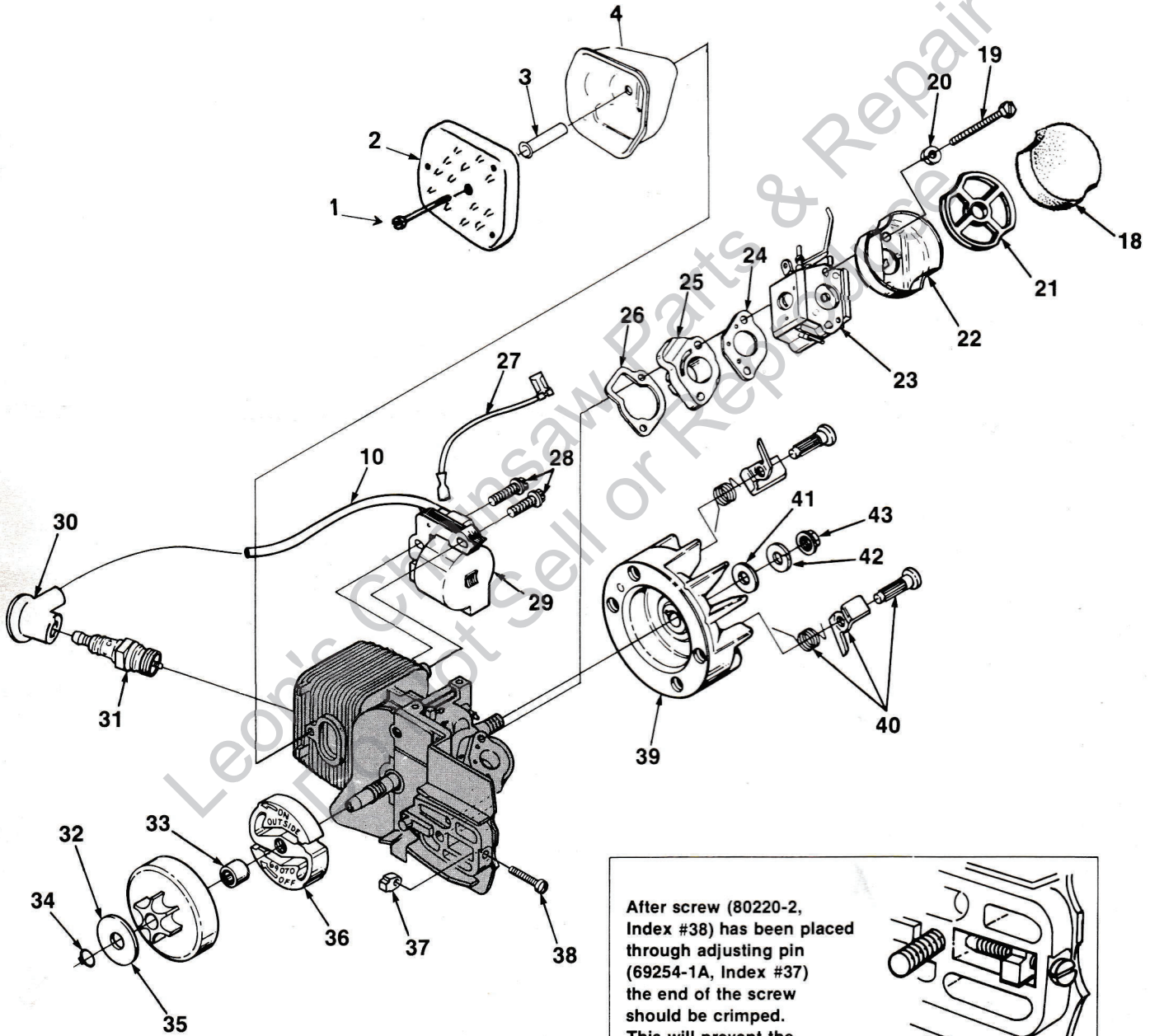
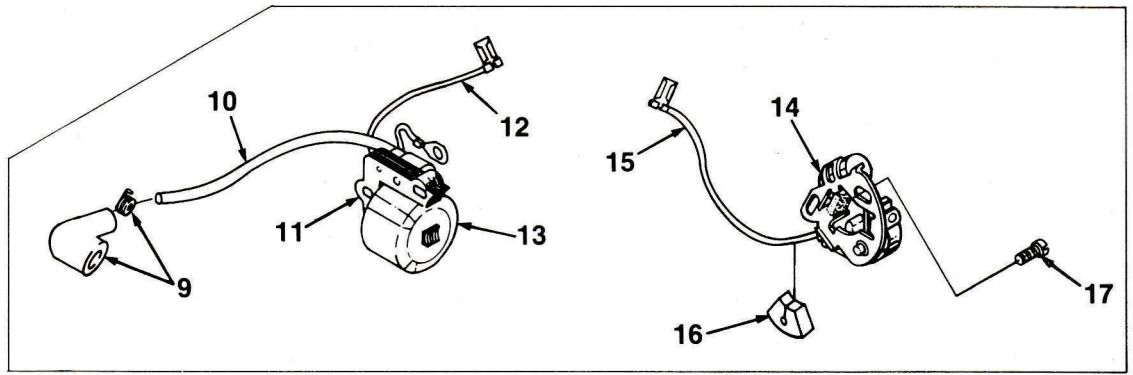

After screw (80220-2, Index #38) has been placed through adjusting pin (69254-1A, Index #37) the end of the screw should be crimped. This will prevent the screw from backing out.

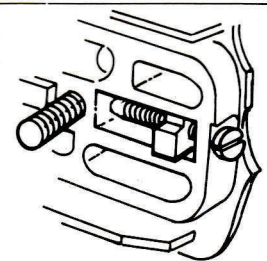

XL-2 FIGURE 2

No.	Description	Part No.	Qty.	No.	Description	Part No.	Qty.
	MUFFLER ASS'Y	A-93686	1	27	LEAD- Ground (Solid State)	A-94721-T	1
	Includes:			28	SCREW- Hex w/washer, 8-32 x 3/4	82248	2
1	SCREW	82320	1	29	MODULE- Ignition (Solid State)	A-94711	1
2	CAP-Muffler	69097-1	1	30	TERMINAL- Spark plug (C/D Ignition)	A-94754	1
3	SPACER	93656-A	1	31	SPARK PLUG- Champion RDJ-7J	78276	1
4	BODY-MUFFLER	69096-1	1	32	SPROCKET & DRUM (6 Tooth 91 & 91S)	A-70221	1
9	TERMINAL- Spark plug (Point Ignition)	A-33055	1		Includes:		
10	LEAD- High tension (Note 1)	69326	1	33	BEARING- Needle	58724-1	1
11	CORE- Coil (Point Ignition)	69324	1	34	RING- Retaining - Clutch	93972	1
12	LEAD- Stop switch (Point Ignition)	69321	1	35	WASHER- Thrust (clutch)	69138	1
13	COIL- Ignition (Point Ignition)	69323	1	36	CLUTCH- "S"	A-70351-T	1
	RETAINER- Coil (Not shown) (Point Ignition)	69325	1	37	PIN- Adjusting (see insert)	69254-1A	1
14	POINT SET- Breaker (Point Ignition)	A-69336	1	38	SCREW- Adjusting (fil hd. 8-32 x 1) (see insert)	80220-2	1
	Includes:			39	ROTOR & STARTER PAWL (Solid State) PHELON	A-94717	1
15	LEAD- Electrical	70249	1		ROTOR & STARTER PAWL (Point Ignition) PHELON	A-69297-A	1
16	SEAL- Lead (Point Ignition)	69247	1		Includes:		
17	SCREW- Point set (Point Ignition)	88026	2	40	PAWL- Starter	A-70285-A	1
18	FILTER- Air	69141	1	41	WASHER- Flat	84065-1	1
19	SCREW- Hex hd., 10-32 x 2 1/4	80481	2	42	WASHER- Lock	83002	1
20	WASHER- Lock, #10	83006-1	2	43	NUT- Rotor-5/16-24	81117	1
21	RETAINER- Air filter	69457	1				
22	CUP- Air filter	69148	1				
23	CARBURETOR- HDC-48A	A-94053	1				
	CARBURETOR- HK-2B	A-70551	1				
24	GASKET- Carburetor	65016	1				
25	MANIFOLD- Intake	A-69373-A	1				
26	GASKET- Intake manifold	69143	1				

NOTE 1: For Solid State Ignition cut wire to 6 1/2".

ACCESSORY

SPROCKET & DRUM (.250 Pitch 9 tooth)	A-69587-A	1
Includes items #33 and #34		

XL-2

FIGURE 3

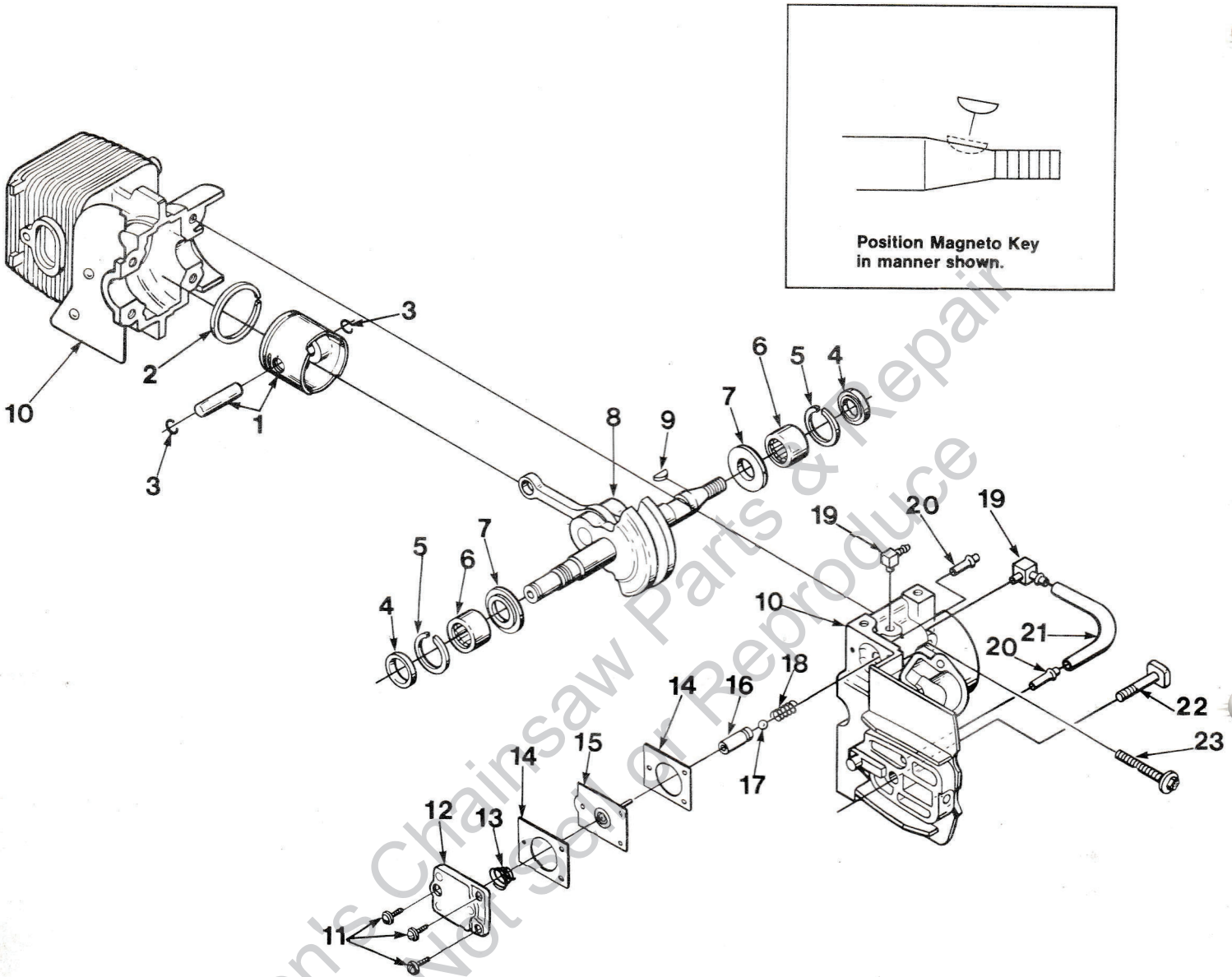

No.	Description	Part No.	Qty.
1	PISTON & PIN Includes:	A-69393-T	1
2	PISTON RING	69312	1
3	RING- Piston pin retaining	65261	2
4	SEAL	94638	2
5	SPACER- Seal	69407	2
6	BEARING- Needle	12530	2
	BEARING- Needle (Opt.)	68513	2
7	WASHER- Thrust	69093-A	2
8	CRANKSHAFT (Solid State)	A-94712	1
	CRANKSHAFT (Point Ignition)	A-78373	1
9	KEY- Magneto (see above)	69250	1
10	CYLINDER & CRANKCASE (Solid State)	A-95071	1
	CYLINDER & CRANKCASE (Point Ignition)	A-69421-B	1
	Includes:		
11	SCREW- Pan hd., 6-32 x 1/2	80630	3

No.	Description	Part No.	Qty.
12	COVER- Oil pump	69224-1C	1
13	SPRING- Oil pump	69447	1
14	GASKET- Oil pump	69244-1	2
15	PLUNGER- Oil pump	A-12356-B	1
16	BODY- Oil pump	69343-1	1
17	BALL- Check valve	60051	1
18	SPRING- Check valve	68570	1
19	FITTING- Oil line	70204	2
20	FITTING- Tube	68571	2
21	LINE- Oil	70161	1
22	BOLT- Guide bar	69195	1
23	SCREW- Sem hex hd. 8-32 x 1	88044	4

**CARBURETOR
A-94053**

HDC-48A

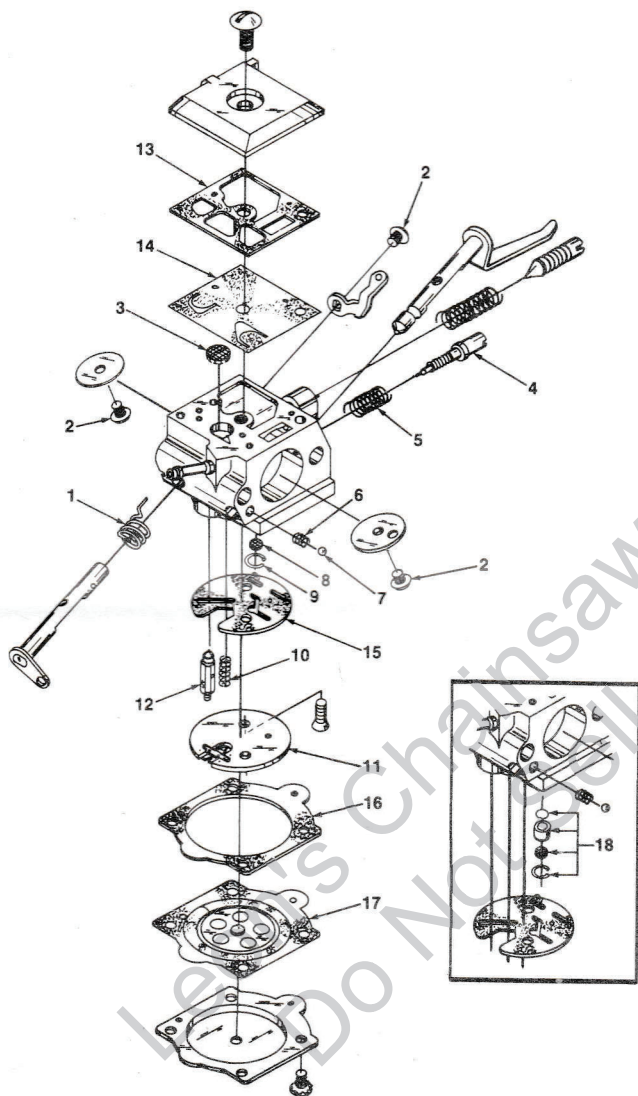

- 94702 Repair Kit (includes 1-17)
- 70655 GASKET/Diaphragm Set (13-17)
- 93910 Check Valve Repair Kit (18)
- 94057 Circuit Plate-High Altitude .029 (not shown)
- 64229 Inlet Needle (12)

**CARBURETOR
A-70551-A**

HK-27A

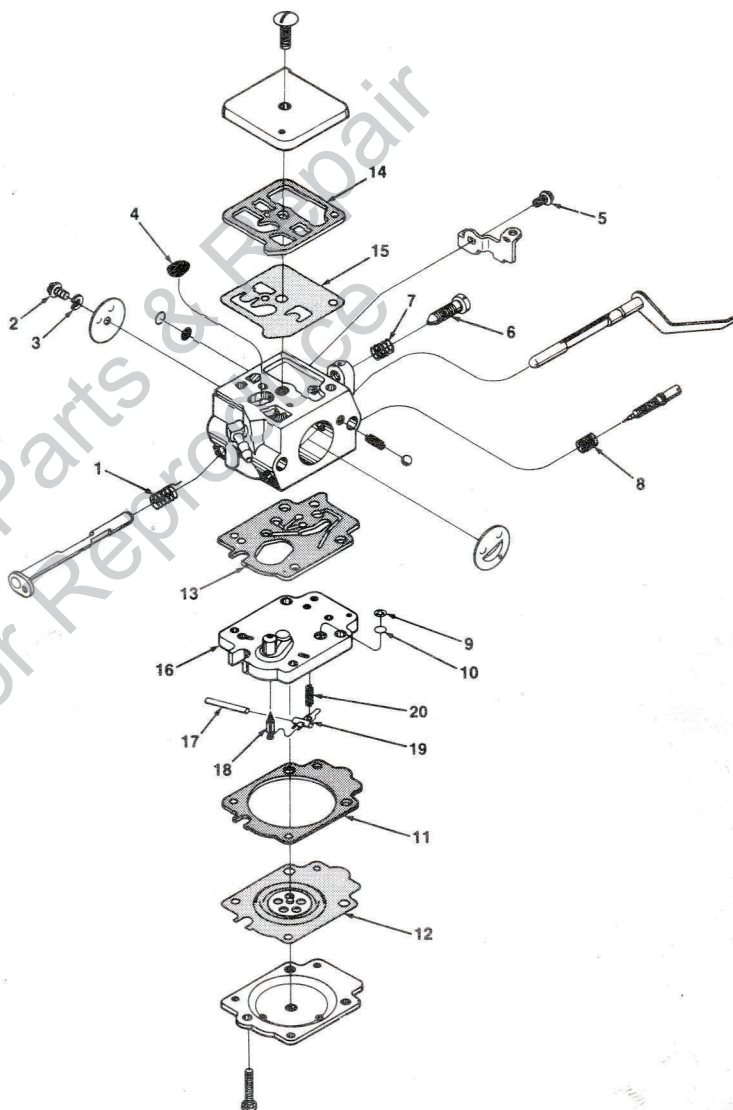

- 94810 Repair Kit (includes 1-15)
- 70094 GASKET/Diaphragm Set (includes 11-15)
- 94817 Module (16) (includes 17-20)
- 70589 High Altitude Kit

XL-2

ACCESSORIES

FILTER- Air	A-24779
Includes:	
FILTER- Air (2)	69141
GASKET- Oil pump body (repair)	69596
KIT- Repair (sprocket nose bar) (.025 pitch)	A-69682-A
KIT- Repair (sprocket nose bar) 91 & 91S pitch	A-70239-B
KIT- Spark arrestor (used with A-93686 Muffler and A-69253-1 Muffler)	A-69586-B
LINE- Fuel (10 ft. length)	70310-99
LINE- Oil (10 ft. length)	93112-99
SAFE•T•TIP	A-70776-T
Includes:	
SCREW- (Special)	93695
GREASE- Multi-use	17193
(Sprocket bearing-PT Guide Bar)	
KIT- Hand guard	A-70796-A
Includes:	
WASHER- Belleville (2)	70728
SPACER- (1)	70748
SCREW- 10-32 x 5/8 (1)	80572
SCREW (1)	82312
CARRYING CASE	94215
STARTING ROPE- 100 ft. reel	#4

TOOLS

SILASTIC- (Crankcase sealing)	24823
PLIERS- TRU-ARC (Sprocket retaining ring)	17198
PULLER- Magneto rotor	A-24747-A
Includes:	
BOLT- 5/16-18 x 1 3/4 (1)	80288
NUT- Hex 5/16-18 (2)	81196
WRENCH- Hex soc., 5/32 (for 10-24 screws)	22126
WRENCH- Hex soc., 9/64	23528
(for socket head connecting rod screws)	
WRENCH- Spanner (clutch)	A-93791
Includes:	
PIN- Clutch spanner (2)	23717-A
TOOL- Carburetor check valve installation	24972

HOMELITE-TERRY **TEXTRON**

Homelite-Terry Division of Textron Canada Limited